



# Horizontal Beer Frosters

- Cabinet made of Galvanized Steel, internally reinforced to support the full weight of the beer bottles
- Full color decals to attract consumers at the point of sale
- Top and Sliding Doors constructed of Stainless Steel
- Modern high-impact plastic motor cover
- UL Classified to ANSI/NSF 7
- Heavy duty condensing unit for R-134a located if front for easy access maintenance
- Forced air condenser
- Forced Air Evaporator for quick temperature made from copper and aluminum, resistant to rust and saline
- UL compliant electrical components



Model No.	Description	Size DxLxH	Voltage	Amps	HP	Cubic Feet	Est. Ship Wt
Froster-B-25-US	1 Door/96 Bottles	26.75" x 25.5" x 35.5"	115	4.3	1/5	5	163#
Froster-B-50-US	2 Door/336 Bottles	26.75" x 50.75" x 35.5"	115	7.6	1/3	15	268#
Froster-B-65-US	3 Door/480 Bottles	26.75" x 65.75" x 35.5"	115	9.2	1/2	21	286#
Froster-B-95-US	4 Door/720 Bottles	26.75" x 95.75" x 35.5"	115	12.6	3/4	31	385#

## Fogel USA

# Horizontal Froster Series



## Technical Data

Model #	Froster-B-25-US	Froster-B-50-US	Froster-B-65-US	Froster-B-95-US
<b>Outside Dimensions</b>				
Depth	26.75"	26.75"	26.75"	26.75"
Length	25.5"	50.75"	65.75"	95.75"
Height	33.625"	33.625"	33.625"	33.625"
Door Size	22.312"x13.375"	(1) 30.5"x13.375" (1) 16.85"x13.375"	(2)22.625"x13.375" (1) 16.85"x13.375"	(3) 23"x13.375" (1) 16.375X13.375"
Door Type	1 sliding	2 sliding	3 sliding	4 sliding
<b>Inside Dimensions</b>				
Depth	22.5"	22.5"	22.5"	22.5"
Length	21.25"	46.5"	61.5"	91.25"
Height	22.5"	22.5"	22.5"	22.5"
# of 12oz Bottles	96	336	480	720
Capacity: Cubic Foot	5	15	21	31
<b>Specifications</b>				
Operating Temperature	23°F-34°F	23°F-34°F	23°F-34°F	23°F-34°F
Refrigerant	R-134a	R-134a	R-134a	R-134a
Compressor Size HP	1/5	1/3	1/2	3/4
Defrost	3 @ 30 min.	3 @ 30 min.	3 @ 30 min.	3 @ 30 min.
Voltage	115	115	115	115
Amperage	4.3	7.6	9.2	12.6
Cord and Plug	yes	yes	yes	yes
<b>Shipping Dimensions</b>				
Depth	27.5"	27.5"	27.5"	27.5"
Length	26.25"	51.5"	66.5"	96.5"
Height	39"	39"	39"	39"
Gross Weight lbs.	163	268	286	385
Cubic feet	20	32	41	60

- Cases are designed to operate at 75° Fahrenheit and 55% relative humidity.
- Specification subject to change without notice.





### Froster-B-25-US and Froster-B-50-US

Side View - Plan View

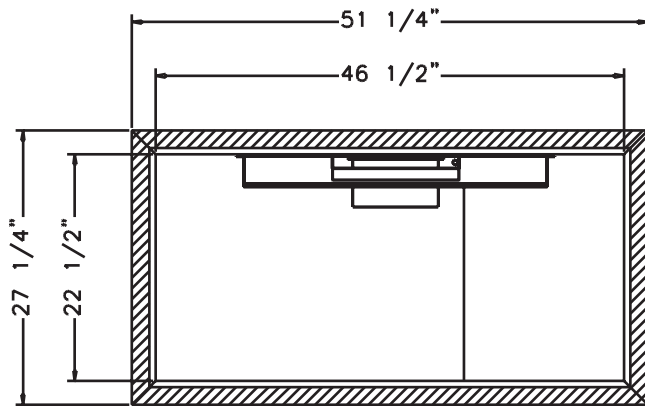

**FROSTER-B-50-US**

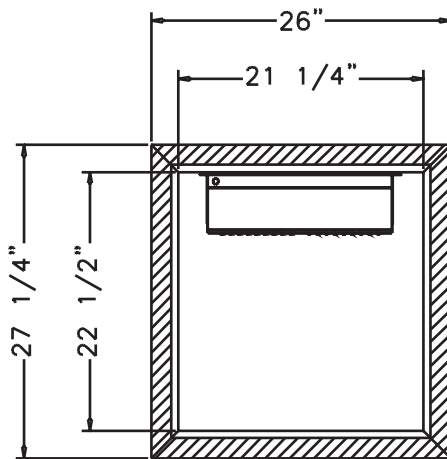

**FROSTER-B-25-US**

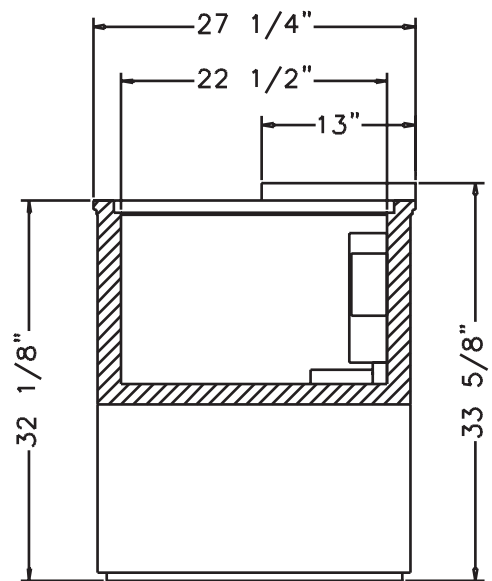

• Specification subject to change without notice.

#### **FOGEL GROUP USA, LLC**

831 E Cayuga Street, Philadelphia, PA 19124 USA • (215) 464-6800 • 1-800-344-8222  
Fax (215) 969-4890 • E-Mail: [sales@fogelusa.com](mailto:sales@fogelusa.com) • [www.fogelusa.com](http://www.fogelusa.com)





### Froster-B-65-US and Froster-B-95-US Side View - Plan View

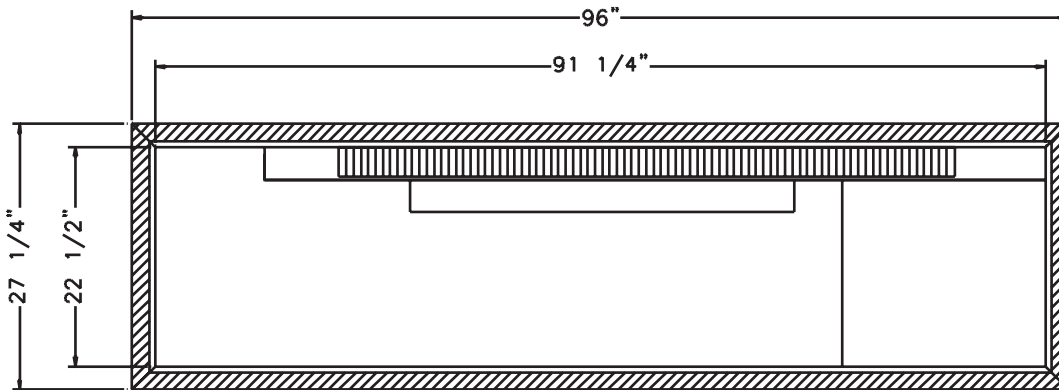

**FROSTER-B-95-US**

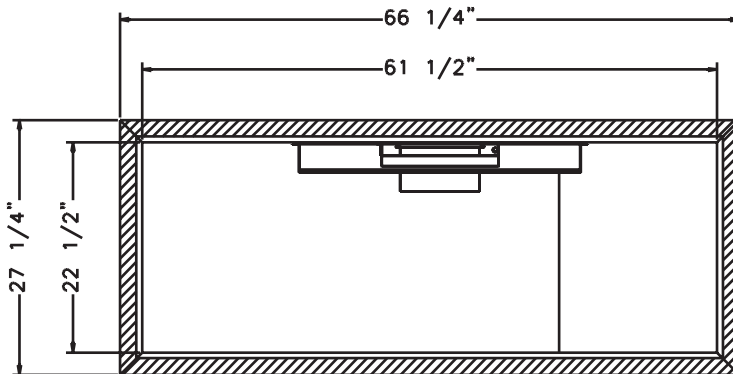

**FROSTER-B-65-US**

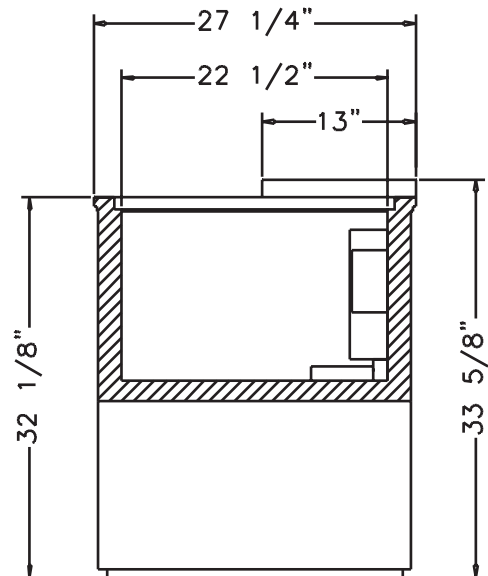

• Specification subject to change without notice.

#### **FOGEL GROUP USA, LLC**

831 E Cayuga Street, Philadelphia, PA 19124 USA • (215) 464-6800 • 1-800-344-8222  
Fax (215) 969-4890 • E-Mail: sales@fogelusa.com • www.fogelusa.com

