

## Glass Door Freezers

- NSF compliant interior cabinet
- Attractive PVC frame with 100% sealing gasket
- Double pane tempered glass door effective for highly humid conditions
- Adjustable screw down Feet for leveling
- Easy access thermostat
- UL Classified to ANSI/NSF 7
- Cases are designed to operate at 75° and 55% relative humidity
- Forced air condenser
- Heavy duty condensing unit with R-134a refrigerant, located in bottom front for easy access maintenance
- 10 year life fan motors
- Refrigeration systems are designed to efficiently cool product even under high ambient conditions
- Illuminated top header sign



CR-23-C-AF-US



CR-49-C-AF-US

Model No.	Description	Size DxLxH	Voltage	Amps	HP	Cubic Feet	Est. Ship Wt
<b>Freezers</b>							
CR-23-C-AF-US	1 Door/4 Shelves	29.5" x 30" x 78"	115	11.0	1	23	335#
CR-49-C-AF-US*	2 Door/8 Shelves	29.5" x 60" x 78"	115*	2@10.9*	2@1*	49	550#

### Fogel USA

# Glass Doors, Hinged–Bottom Mount Freezer



## Technical Data

Model #	CR-23-C-AF-US	CR-49-C-AF-US
<b>Outside Dimensions</b>		
Depth	29.5"	29.5"
Length	30"	60"
Height	78"	78"
Door Size	30" x 51.75"	30" x 51.75"
Door Type	1 swing	2 swing
<b>Inside Dimensions</b>		
Depth	25.25"	60.37"
Length	25.25"	55.25"
Height	60.37"	60.37"
Shelf Size	24.56"x23.125"	24.56"x23.125"
# of Shelves	4	8
Capacity: Cubic Foot	23	49
<b>Specifications</b>		
Operating Temperature	-5°F to 5°F	-5°F to 5°F
Refrigerant	R-404A	R-404A
Compressor Size HP	1	1
Defrost	3 @ 30 min.	3 @ 30 min.
Voltage	115	115 (2 units)
Amperage	11.0	10.9 per unit
Cord and Plug	yes	yes (2)
<b>Shipping Dimensions</b>		
Depth	31.875"	31.875"
Length	32.375"	62.375"
Height	81.75"	81.75"
Gross Weight lbs.	335	550
Cubic feet	48	92

- Cases are designed to operate at 75° Fahrenheit and 55% relative humidity.
- Specification subject to change without notice.
- CR-49C-AF-SA-US has two individual condensing units, one for each section





# Glass Doors, Hinged-Bottom Mount Freezer

Technical Data - Side View - Plan View

## CR-23-C-AF-US and CR-49-C-AF-US

Side View - Plan View

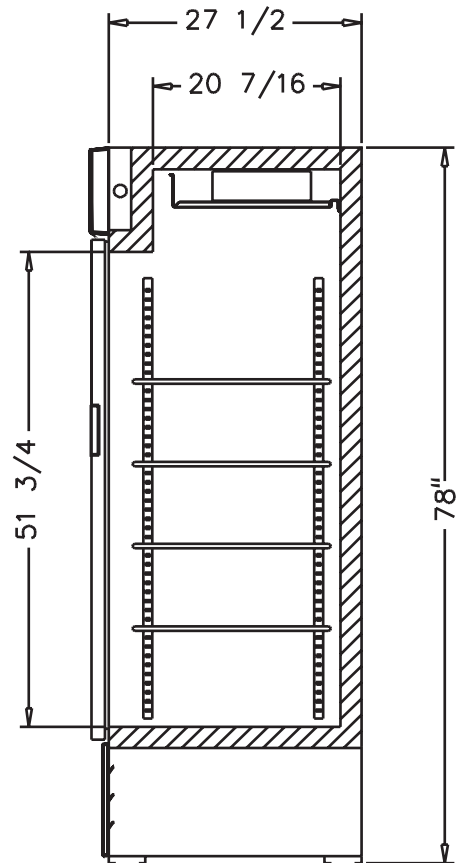
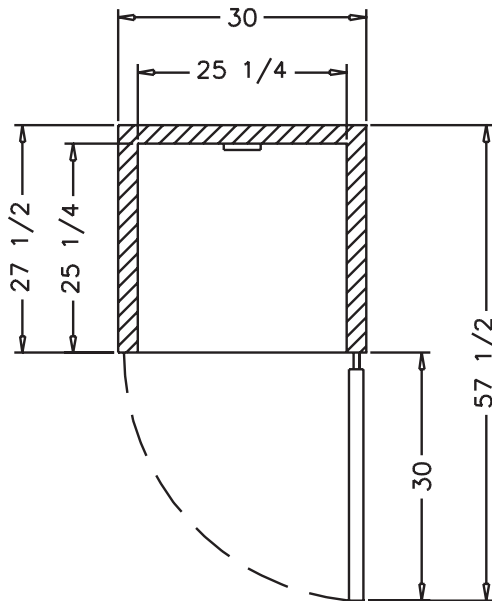
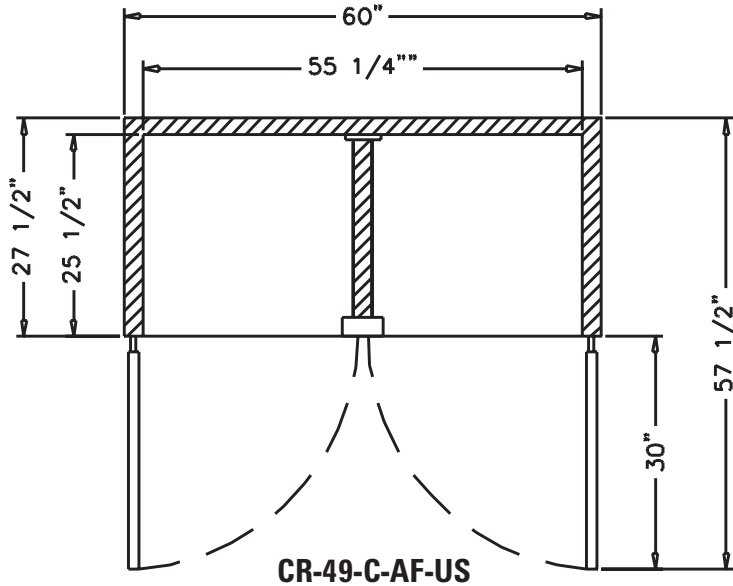

• Specification subject to change without notice.

### FOGEL GROUP USA, LLC

831 E Cayuga Street, Philadelphia, PA 19124 USA • (215) 464-6800 • 1-800-344-8222  
Fax (215) 969-4890 • E-Mail: [sales@fogelusa.com](mailto:sales@fogelusa.com) • [www.fogelusa.com](http://www.fogelusa.com)

